

Hardware Interface Description

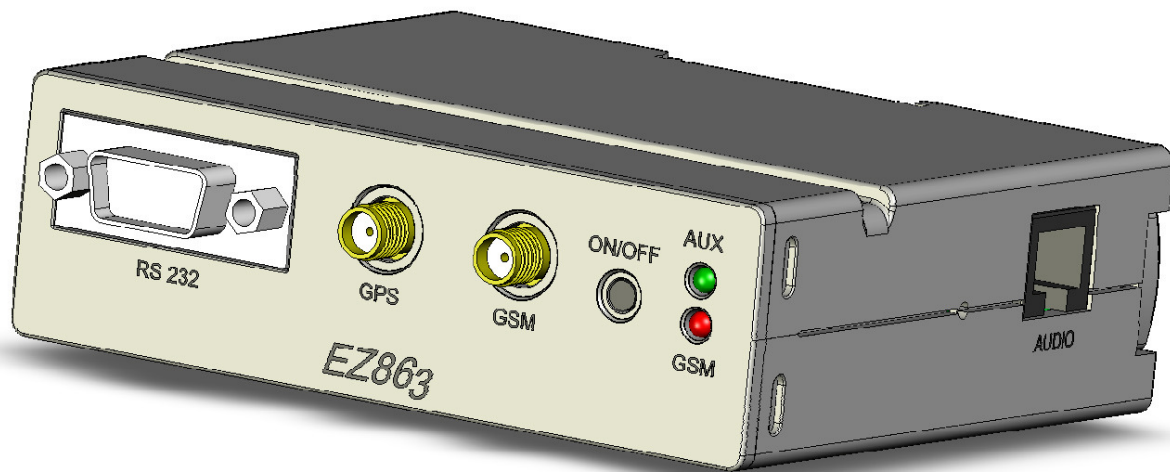

EZ863 GPS Terminal Telit Cellular GPS Engine

Version: 04.01
EZ863 GPS Terminal_HD_V4. 02.SEP.2008

1. Key Features of the EZ863 GPS Terminal

Feature	Implementation
General	
Incorporates GE863 GPS module	The Telit GE863 GPS module handles all processing for audio, signal and data within the EZ863 Terminal.
Frequency bands	Quad band: GSM 850/900/1800/1900MHz
Power supply	Single supply voltage 6V to 30V
Operating temperature	-20°C to +70°C ambient temperature
Physical	Dimensions: 98mm x 82m x 30m Weight: 160g , with battery 180g
RoHS, WEEE	All hardware components are fully compliant with the EU RoHS and WEEE Directives
Incorporates Micro controller PIC16F630 for Watch dog	The Micro controller handles all watch dog for PYHTON and Cellular network, signal IGNITION and Movement sensor.
GSM / GPRS features	
Data transfer	GPRS · Multislot Class 10 CSD · 2.4, 4.8, 9.6 kbps · USSD PPP-stack for GPRS data transfer
SMS	· Point-to-point MT and MO · Text and PDU mode · Storage: SIM card plus 20 SMS locations in mobile equipment · Transmission of SMS alternatively over CSD or GPRS. Preferred mode can be user defined.
Fax	Group 3; Class 1
Audio	Speech codecs: · Full rate FR · Enhanced full rate EFR · Adaptive Multi Rate AMR Line echo cancellation
Software	
AT commands	AT-Hayes GSM 07.05 and 07.07
TCP/IP Stack.	TCP/IP stack Access by AT commands
Firmware update	Upgradeable via serial interface.

PYTHON platform	Major benefits: seamless integration into PYTHON applications, no need for application microcontroller, extremely cost-efficient hardware and software design – ideal platform for industrial GSM applications. The memory space available for PYTHON programs is 3.0 MB flash file system and 1.5 MB RAM. Application code and data share the space in the flash file system and in RAM.
Interface	
Serial interface	<ul style="list-style-type: none"> · 8-wire modem interface with status and control lines, unbalanced, asynchronous · Fixed bit rates: 300 bps to 115,200 bps · Autobauding: 300 bps to 38,800 bps · Multiplex ability according to GSM 07.10 Multiplexer Protocol.
I ² C	bus for transmission rates up to 10kbps. The I ² C interface is not available when using as GPIO interface on the same pin out.
Audio	Analog (Microphone amplifier ready, Speaker with 3W amplifier)
SIM interface	Supported SIM cards: 3V
Antenna	Connected via antenna SMA connector or internal antenna
Power on/off, Reset	
Power-on	<ol style="list-style-type: none"> 1. Automatic on when power supply turn on 2. Switch on via On/Off push button 3. On/Off line on IO interface connector 4. When IGNITION ON Micro will start up the modem
Power-off	Normal switch-off by AT or On/Off push button PYTHON script switch OFF
Reset	Shutdown and reset by AT command
Special features	
Real time clock	Timer functions via AT commands
GPIO	8 I/O pins of the application interface are programmable as GPIO. Programming is done via AT commands. Alternatively, 4 Output pins of the application interface are Open Collector. GPIO3, GPIO4 are configurable as I ² C by AT command. If the I ² C is active the GPIO3 and GPIO4 are not available.
ADC input	Analog-to-Digital Converter input for measuring external voltages. Optional internal measuring supply voltage to the unit.
Phonebook	SIM and phone
GPS	High sensitivity for indoor reception up to -159 dBm. Fast TTFF's at low signal levels. Hot starts less then 2 seconds. Support 20- Channel GPS. GPS NMEA 0183 output format.

2. Interface Description

2.1 Overview

EZ863 GPS Terminal provides the following connectors for power supply, interface and antennas:

1. On/Off push button.
2. SMA connector (female) for GSM antenna.
3. GSM Led and GPIO10 Led.
4. 9-pole (female) SUB-D plug for RS-232 serial interface.
5. SMA connector (female) for GPS antenna.
6. 24-pole GPIO 3mm Micro Mate-N-LOK connector for GPIOs, I²C, ADC, Power.
7. 4-pole 3mm Micro Mate-N-LOK connector for power supply, RTS and Ignition input.
8. 6-pole RJ11 plug (female) for audio accessory, such as a Microphone and Speaker.
9. SIM card holder.

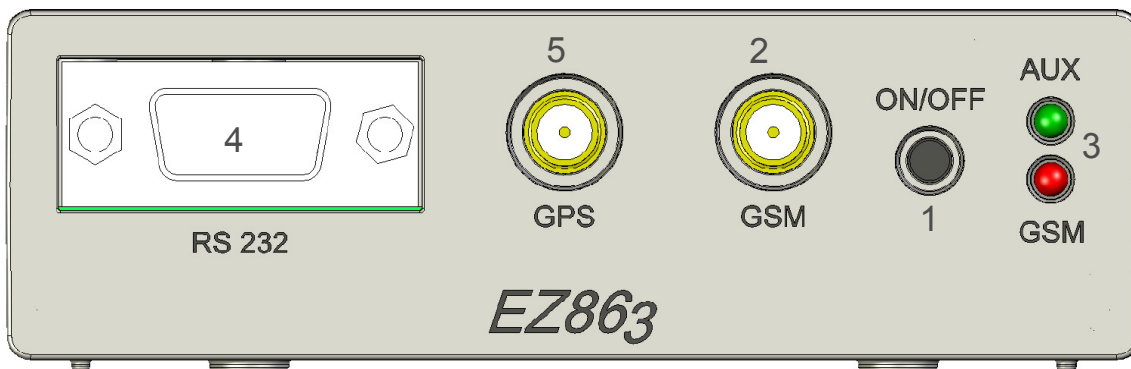

Figure 1: EZ863 Terminal front view

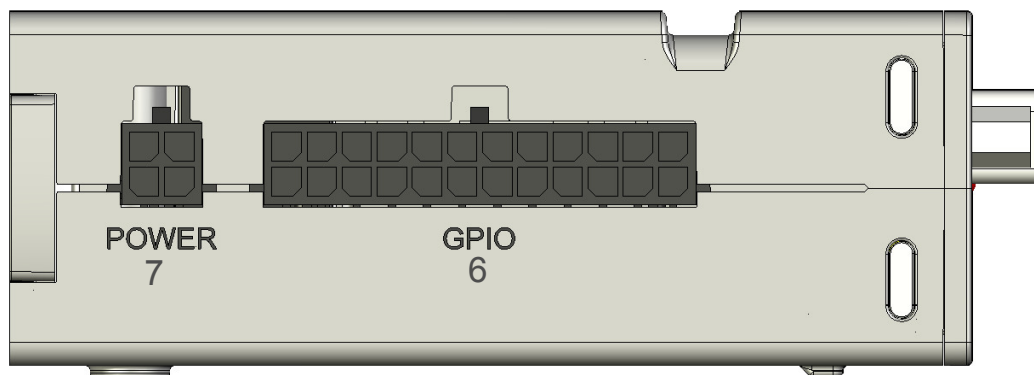

Figure 2: EZ863 Terminal side A view

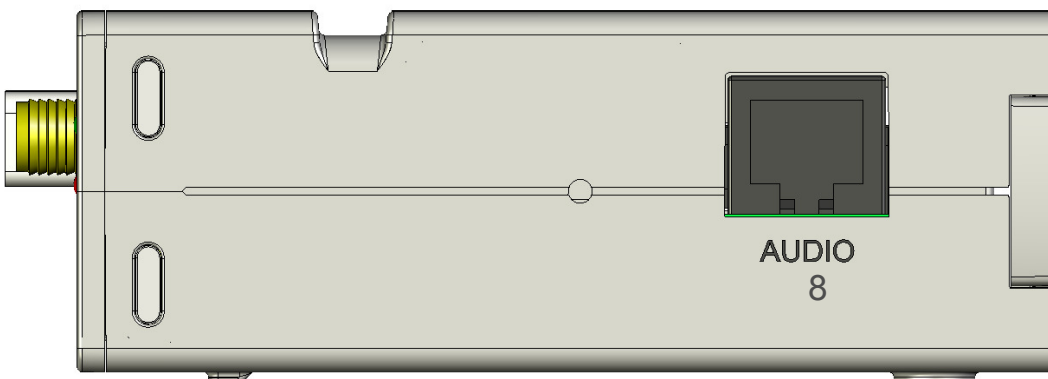

Figure 3: EZ863 Terminal side B view

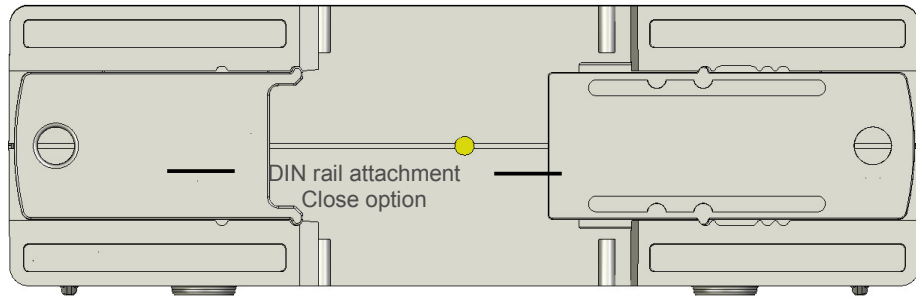

Figure 4: EZ863 Terminal rear view 1- DIN rail attachment close

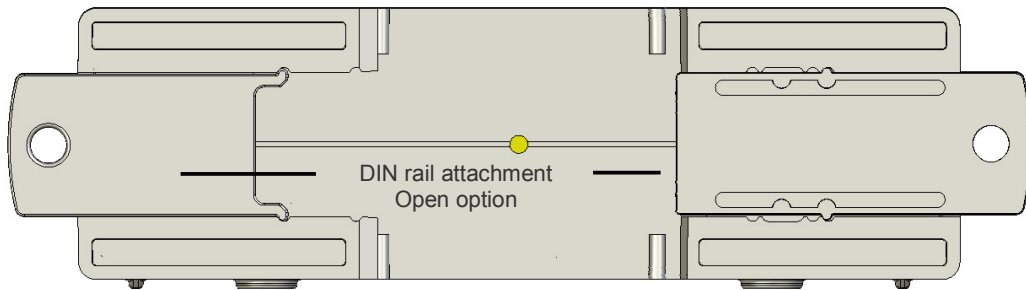

Figure 5: EZ863 Terminal rear view 2 – DIN rail attachment open

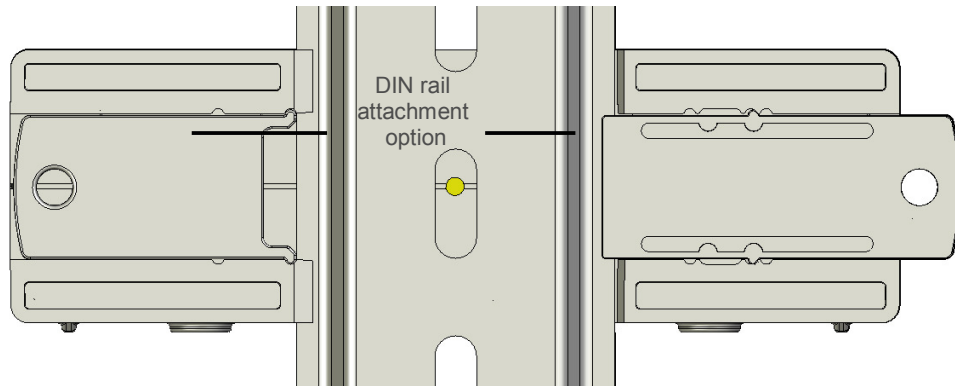

Figure 6: EZ863 Terminal rear view 3 – DIN rail attachment lock on DIN rail

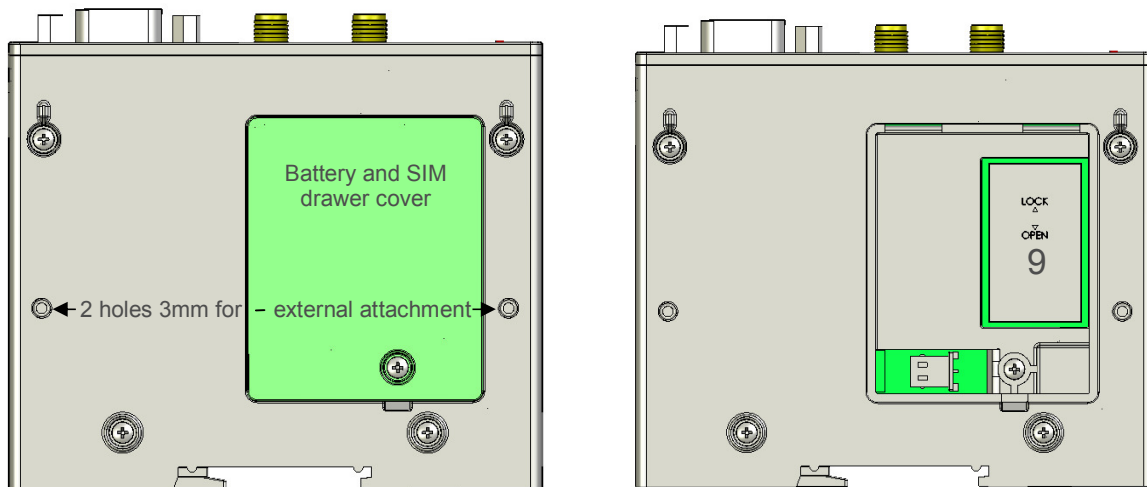

Figure 7: EZ863 Terminal bottom view

2.2 Block Diagram

Figure 8 shows a block diagram of a sample configuration that incorporates a EZ863 GPS Terminal and typical accessories.

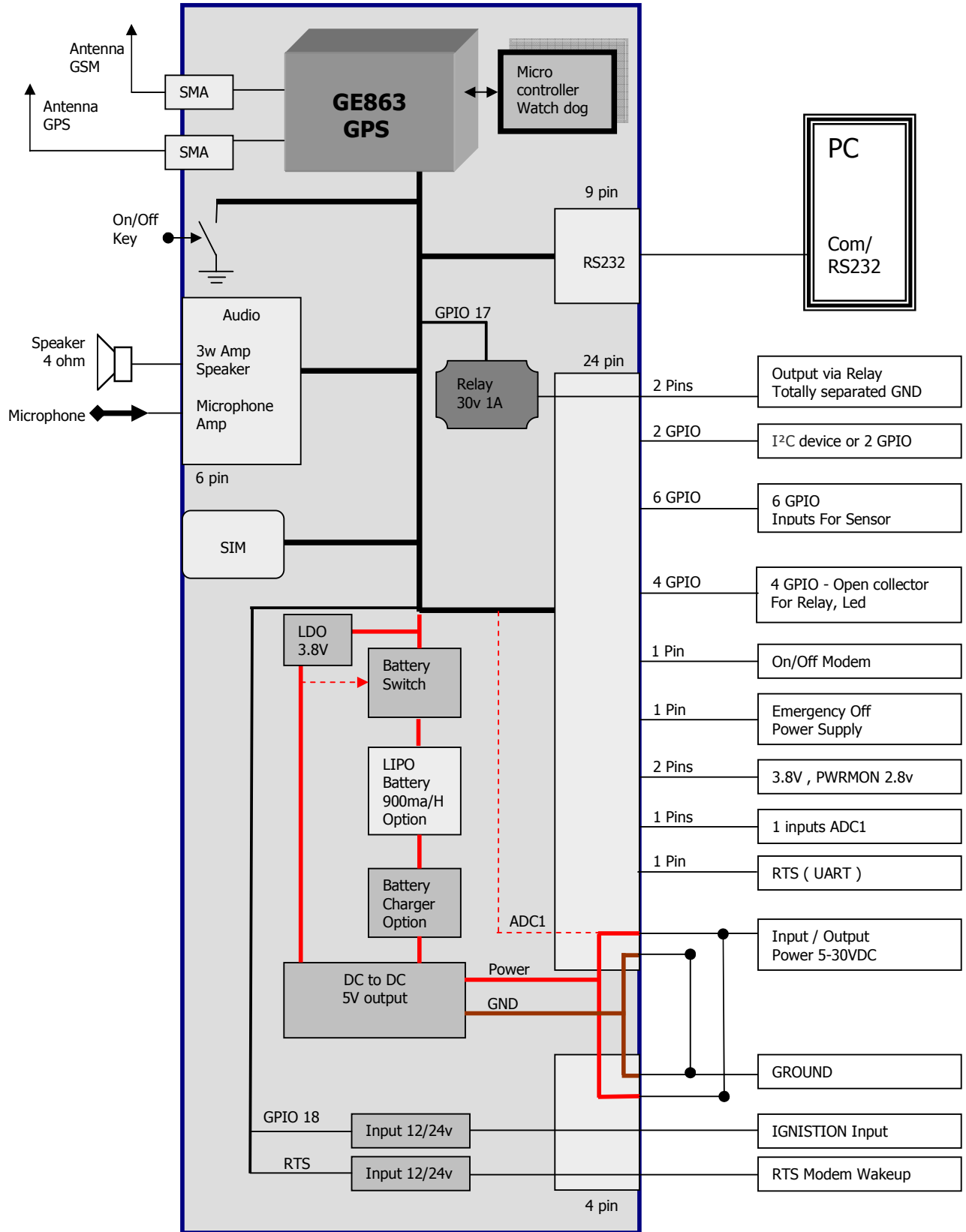

Figure 8: Block diagram EZ863 GPS

EZ863 V4 hardware Micro controller software application for AVL

1. IGNITION

a. When IGNITION ON:

Micro start up the DC/DC 20sec after IGNITION ON, Then turn ON the Modem via ON/OFF.
(GPIO18 is LOW when IGNITION ON)

b. When IGNITION OFF:

The MICRO will not turn OFF the Modem, Modem will turn him self OFF with PYTHON script.
(GPIO18 is HIGH when IGNITION OFF)
(Suggestion: PYTHON software design to turn OFF the Modem when the IGNITION OFF,
GPIO18 will Give indication to the Modem that IGNITION OFF)

c. GPIO18 (IGNITION) can be disconnected from Micro with SW1-3

2. MOVMENT SENSOR

a. When Modem OFF:

Micro sense the MOVEMENT SENSOR, if there is movement, Micro change GPIO9 from **HIGH** to **LOW**, then Micro Turn ON the DC/DC and then turn ON the Modem, Micro wait for GPIO6 to go **LOW**, GPIO6 indicate to the Micro that Modem finish to start up of the Modem and the PYTHON script (Suggestion - PYTHON software design so: checking the GPIO9 status then change GPIO6 from **HIGH** to **LOW** for 10 sec). When GPIO6 go **LOW** Micro will start new session of testing MOVEMENT SENSOR.
Note: GPIO9 and GPIO6 normally **HIGH** with internal pull up 10k.

b. When Modem ON:

Micro sense the SENSOR MOVEMENT, if there is movement, Micro change the GPIO9 from **HIGH** to **LOW** and wait for GPIO6 to go **LOW**, this will notify the Micro to start new testing for MOVEMENT SENSOR. (Micro makes calculations to decide that MOVEMENT SENSOR is a true movement)

c. GPIO9 (MOVEMENT SENSOR) can be disconnected from Micro with SW1-2

d. Micro will not sense the MOVEMENT SENSOR for five minuses from IGNITION OFF.

3. WATCH DOG

- Modem GPIO6 have to go **LOW** each 20min, this will indicate that the PYTHON script still running and no need to restart the Modem. Micro check GPIO6 if for 20min will remain **HIGH** Micro will restart the Modem. Micro checks the POWER MONITOR pin to decide if Modem is in **ON** or **OFF** condition, the WATCH DOG working only when Modem is ON. (The PYTHON software designs so the GPIO6 will go LOW for 10sec each 10min).
- Modem LED have to change status each 1hour, this will be use as second backup WATCH DOG, if Micro will not detect change on the Modem LED will restart the Modem, this test check Modem connection to the network. (NOTE: Modem LED will stay ON when Modem is in call connection)
(PYTHON script consideration: audio call will not be longer then 1hour)
- Modem LED blinking 50% ON/OFF for over 5min, means: Modem fail connection to network, over 5min Micro will restart the Modem. (Micro will start up new counting, each Modem start up, check by Power Monitor Pin)
PYTHON script design to check network connection and restart Modem if no connection each 4min)
- GPIO6 (WATCH DOG) can be disconnected from Micro with SW1-5

4. DC/DC POWER OFF

- The Modem will notify the Micro to turn OFF the DC/DC by change the GPIO14 from **HIGH** to **LOW**, The Micro will turn OFF the DC/DC 1min after the GPIO14 command send.
(the Modem can not turn OFF the DC/DC)
Note: GPIO14 normally **HIGH** with internal pull up 10k.
- The DC/DC power supply will consume 15-20ma when Modem is OFF, when DC/DC set to OFF the input power will run only the Micro and will be lower then 1ma.
- The Micro DC/DC control pin will turn **OFF** the RS232 level translator and Audio Amplifier as well.
- DC/DC control can be disconnected from Micro with SW1-4

5. BATTERY MESERMENT

- Micro measure the Battery voltage with internal comparator, the comparator will detect voltages level, under 3.6V Micro will turn ON the DC/DC that supply power to the Battery charger that will charge the Battery, over 4.0V the Micro will wait 1hour and then turn OFF the DC/DC that supply power to the Battery charger.
- The internal Battery charger will take care of the normal charging stage of the LIOP Battery.
- When Modem working on the battery power, Modem can check the battery voltage by AT command AT#CBC

6. LED

Indicate Micro status (YELLOW LED).

- LED blinking every 3sec _ normal.
- LED blinking every 1sec _ error.
- LED ON _ Modem restart

7. INPUT VOLTAGE DETECTION

- Micro senses the VIN FAIL (INPUT VOLTAGE), Micro Turn ON the DC/DC and then turns ON the Modem, this function will work only when backup battery exist
(Suggestion: PYTHON software design to check ADC1 status on start up, ADC1 of the Modem gives the VIN voltage measurement)

8. PYTHON APPLICATION NOTES

When modem start up the PYTHON script has to check up on what condition was the wake up:

- PYTHON script check MOVEMENT SENSOR (GPIO9)
- PYTHON script check IGNITION (GPIO18)
- PYTHON script check INPUT VOLTAGE FAIL (ADC1)
- PYTHON script notify MICRO that all been tested by changing GPIO6, GPIO6 use also as WATCH DOG for the PYTHON.

2.2.1 Block Diagram EZ863 GPS V4 WATCH DOG OPTION

Figure 9 shows a block diagram of Micro controller connection to EZ863 GPS Terminal.

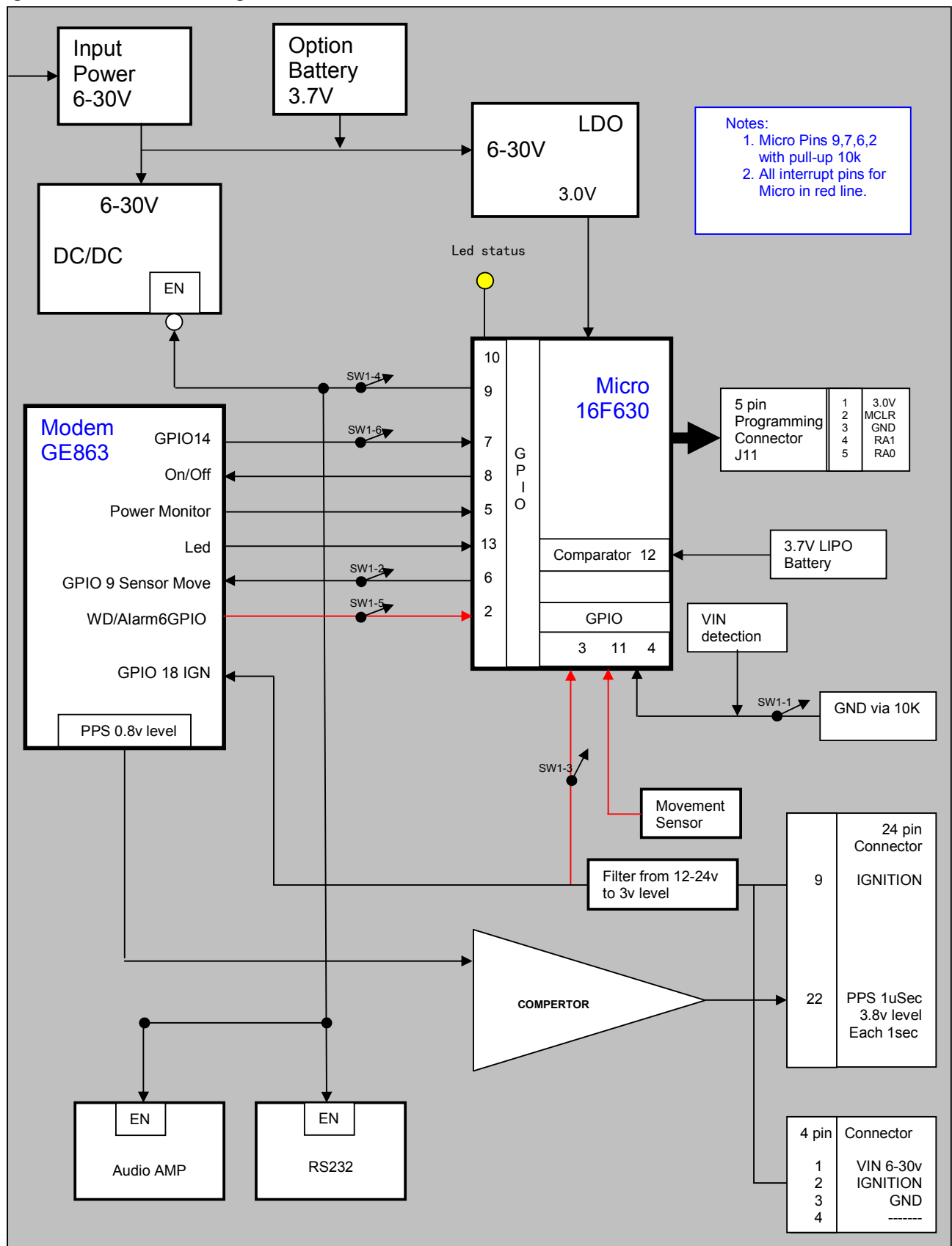

Figure 9: Block diagram Micro connection in EZ863 GPS

2.3 Power Supply

The power supply of the EZ863 GPS Terminal has to be a single voltage source of POWER 6V-30V capable of providing a peak during an active transmission. The EZ863 Terminal is protected from supply reversal voltage. An internal fuse ensures an electrical safety according to EN60950. This fuse is not removable. A fast acting fuse 0.8A with melting is necessary to use with the EZ863 GPS Terminal at a 24V power supply system for vehicles. The power supply must be compliant with the EN60950 guidelines.

Pin	Signal name	Use
1	POWER	Input Power supply range 6-30V
2	IGNITION	Power on console connected to GPIO 18 - input 12-24V
3	GND	Ground
4	-----	-----

Table 1: Pin assignment of the plug for power supply and relay

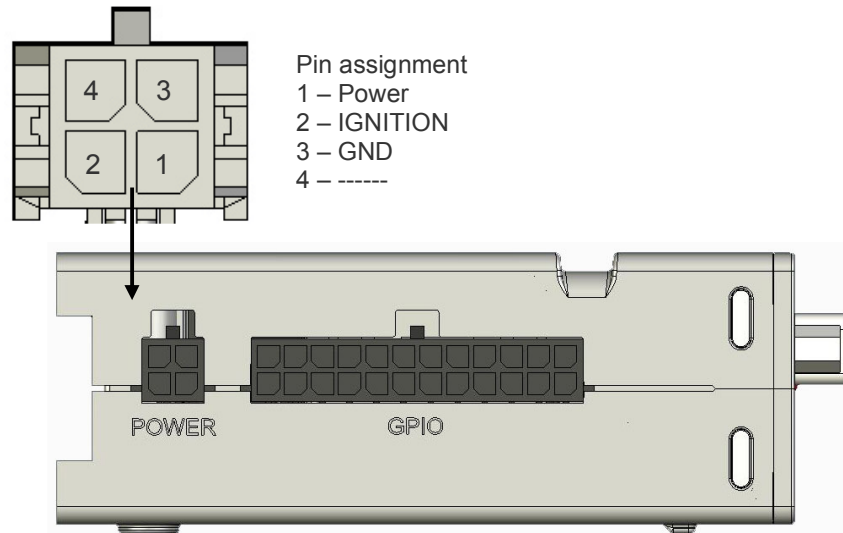

Figure 10: Male 4-pole plug for power supply.

2.3.1 Supply voltage requirements

The DC power supply must be connected to the POWER input:

- Input voltage range 6 - 30V DC
- Nominal Voltage 12V DC
- Power Supply current rating: min. 1,2A @12V
- Power Supply ripple: max. 120mV
- Input current in idle mode: 20mA @ 12V
- Input average current in communication mode: 100mA @ 12V

2.3.2 Block Diagram Battery management

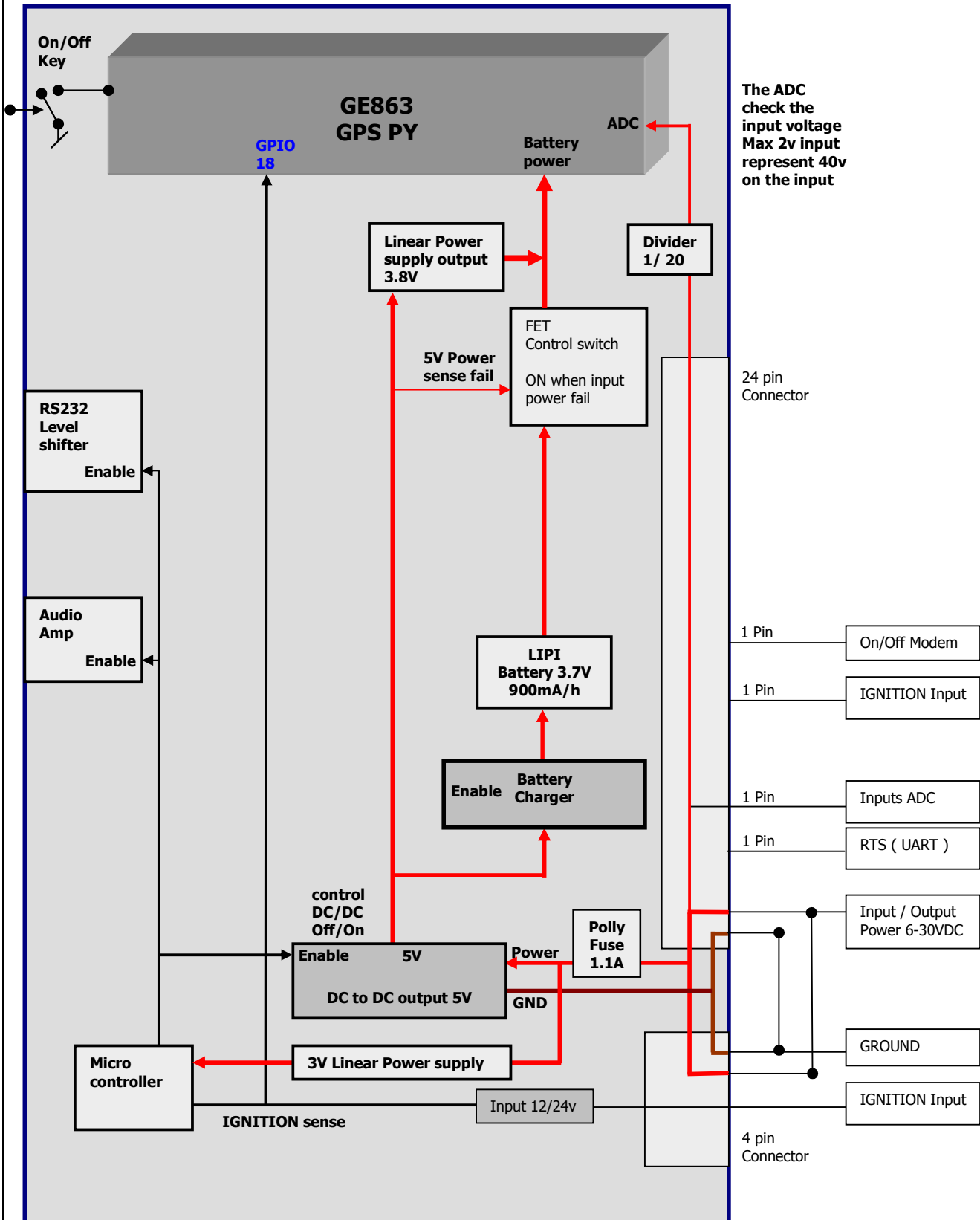

Figure 11: Block diagram EZ863 GPS energy management

2.3.3 Block Diagram Battery management flow chart explanation

EZ863 GPS Power supply

Input power 6-30 VDC, the input power pass via poly fuse and over voltage and reverse polarity protection. The DC/DC reduce the power to 5V, the 5V supply for two separate direction,

- A. First direction to Linear power supply that reduce the power to 3.8V, this power supply will hold the unit power on regular base
- B. Second direction to battery charger, the battery charger supply the LIPO battery the correct power management, battery selected 960ma/H max size 38*39*6.1mm with internal management card, on normal operation the battery will be charge to maximum 4.1V, the battery is use for backup and supply the power to the modem only when the main power fail or when the modem turn off the DC/DC power supply.

The EZ863 GPS automatically will switch from linear power supply to battery operation when the DC/DC power supply stops 5V output.

EZ863 GPS controls

Modem control the DC/DC via Micro controller,

Modem sense the Ignition status via GPIO 18,

Modem wakeup from sleep mode with Micro sense the IGNITION signal,

Modem measure Input voltage with ADC (ratio 1/20), (only on EZ863 GPS version 4)

LIPO battery can be charge only when temperature is 5-45°

Modem control the Audio amplifier and the RS232 level shifter via Micro controller,

2.4 Switch on EZ863 GPS Terminal

There are several ways to turn on the EZ863 GPS Terminal:

- Switch on via On/Off push button, switch on the EZ863 GPS Terminal by pressing the On/Off key or via On/Off signal line on IO interface connector:

The On/Off pin of the 24 pins connector is connected in parallel to the On/Off key and makes possible to control the EZ863 GPS Terminal from a remote unit.

signal line must be asserted for at least 1000 ms and then released.

- Switch on via automatic power supply unit:

By connecting the EZ863 GPS Terminal with the power supply unit the EZ863 GPS Terminal starts to work.

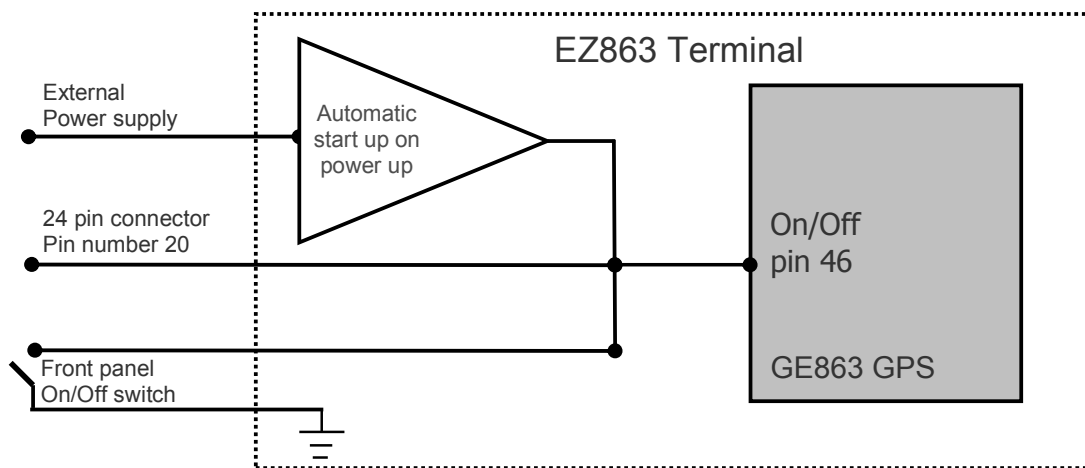

Figure 12: On/Off control

2.4.1 Reset EZ863 GPS Terminal

An easy way to reset the EZ863 GPS Terminal is entering the command AT+CFUN=x,1.

2.4.2 Switch Off EZ863 GPS Terminal

There are several ways to turn off the EZ863 GPS Terminal:

- Software controlled shutdown by AT command:
The AT command lets EZ863 GPS Terminal log off from the network and allows the software to enter into a the secure state and save data before disconnecting the power supply. The mode is referred to Power-down mode. In this mode only the RTC stays active.
- Software controlled shutdown via On/Off push button or On/Off line at IO interface connector:
The EZ863 GPS Terminal will be switched off by pressing the On/Off push button or by activating the On/Off signal for >1s.

2.4.3 Disconnecting Power Supply

Before disconnecting the power supply from the POWER pin make sure the EZ863 GPS Terminal is in a safe condition. A safe condition is waiting 1s after the "SHUTDOWN" result code has been indicated.

2.5 Signal States after Startup

Table 7 describes the various states each interface pin passes through after startup and during operation. The state of several pins will change again once the respective interface is activated or configured by AT command.

24 Pin Connector	Signal name	Undefined state during startup	Defined state After initialization	Active state after configuration by AT command	
				GPIO	I2C
1	I2C CLK - IO3	I	Tri state	IO	O, OD
2	I2C DAT - IO4	L	Tri state	IO	I, O
3	GPIO1	I, PU	I, PU	I	
4	GPIO8	I, PU	I, PU	I	
15	GPIO12	I, PU	I, PU	I	
16	GPIO11	I, PU	I, PU	I	
17	GPIO15	I, PU	I, PU	I	
18	GPIO16	I, PU	I, PU	I	
5	GPIO7	O, OC	O, OC	O	
6	GPIO2	O, OC	O, OC	O	
7	GPIO5	O, OC	O, OC	O	
8	GPIO13	O, OC	O, OC	O	
13	Relay out 1	OPEN	OPEN	CLOSE	
14	Relay out 1	OPEN	OPEN	CLOSE	
19	PWRMON	0V	2.8V	0V	
10	RTS	I, PU	I, PU		

Table 2: Signal states

Abbreviations used in Table 2:

L/H = Low or high level

I = Input

O = Output

OD = Open Drain

OC = Open Collector

PU = Pull up

2.5.1 GPIO Interface Specification

All General Purpose input / output are connected to the related pins of the Telit module over a 100 Ohms series resistor. The following table shows the logic level specifications in the EZ863 GPS terminal interface circuits:

LEVEL	MIN	MAX
Input high level	2.1 V	3.6V
Input low level	0 V	0.5 V
Output high level	2.2 V	3.0 V
Output low level	0 V	0.35

Table 3: GPIO Signal states level

2.6 RS-232 Interface

The serial interface of the EZ863 GPS Terminal is intended for the communication between the GSM module and the host application. This RS-232 interface is a data and control interface for transmitting data, AT commands and providing multiplexed channels. EMC immunity complies with the vehicular environment requirements according to EN 301 489-7.

The user interface of the EZ863 GPS Terminal is accessible from a Data Terminal Equipment DTE connected to the RS232 interface and it is managed by AT commands according to the GSM 07.07 and 07.05 specification and the supported commands are listed in the AT Commands Reference Guide.

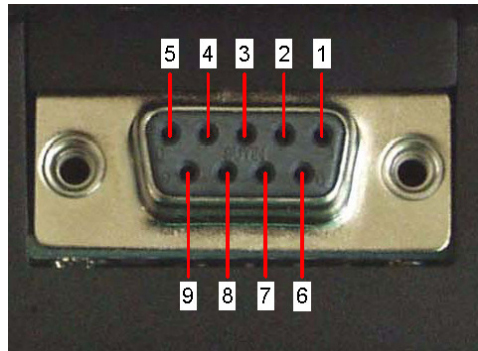

Figure 13: Pin assignment RS-232 (D-Sub 9-pole female)

Pin no.	Signal name	I/O	Function of application
1	DCD	O	Data Carrier Detected
2	RXD	O	Receive Data
3	TXD	I	Transmit Data
4	DTR	I	Data Terminal Ready
5	GND	-	Ground
6	DSR	O	Data Set Ready
7	RTS	I	Request To Send
8	CTS	O	Clear To Send
9	RING	O	Ring Indication

Table 4: D-Sub 9-pole female RS232

Connector type on the terminal is:

- RS-232 through D9-pin female
- Baud rate from 300 to 115.200 bit/s
- Autobauding (300 to 38.400 bit/s)
- Short circuit (to Ground) protection on all outputs.
- Input voltage range: -12V to +12V

2.6.1 The PC as Data Terminal Equipment (DTE)

The software application for using the PC RS232 standard serial interface (COM-port) as Data Terminal Equipment (DTE) is usually Hyper Terminal. Connect using the COM-port to which the EZ863 GPS Terminal is connected with the following settings:

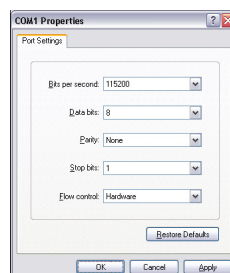

EZ863 Terminal Hardware Interface Description
Released

2.7 Audio Interface

The audio interface provides one analog input for a microphone and one analog output for Speaker.

- The microphone input and the Speaker output are balanced.
- For electret microphone a supply source is implemented.
- For speaker 3W amplifier implemented output 4ohm.

Pin assignment

- 1 – GND
- 2 - MICP (-Microphone, Bias)
- 3 - EPRP (Speaker 4ohm 3w)
- 4 - EPRN (Speaker 4ohm 3w)
- 5 - MICN (+Microphone, Bias)
- 6 - 3.8V

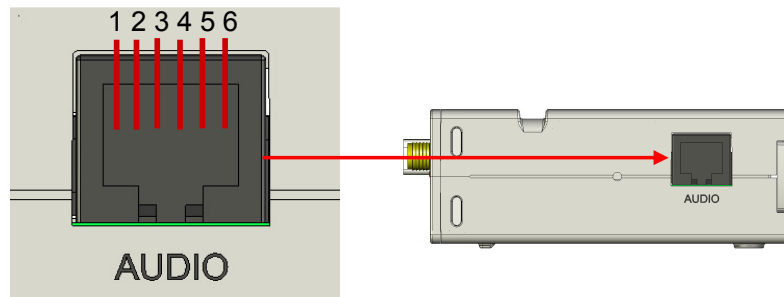

Figure 14: Audio RJ11 plug (6/4-pole female)

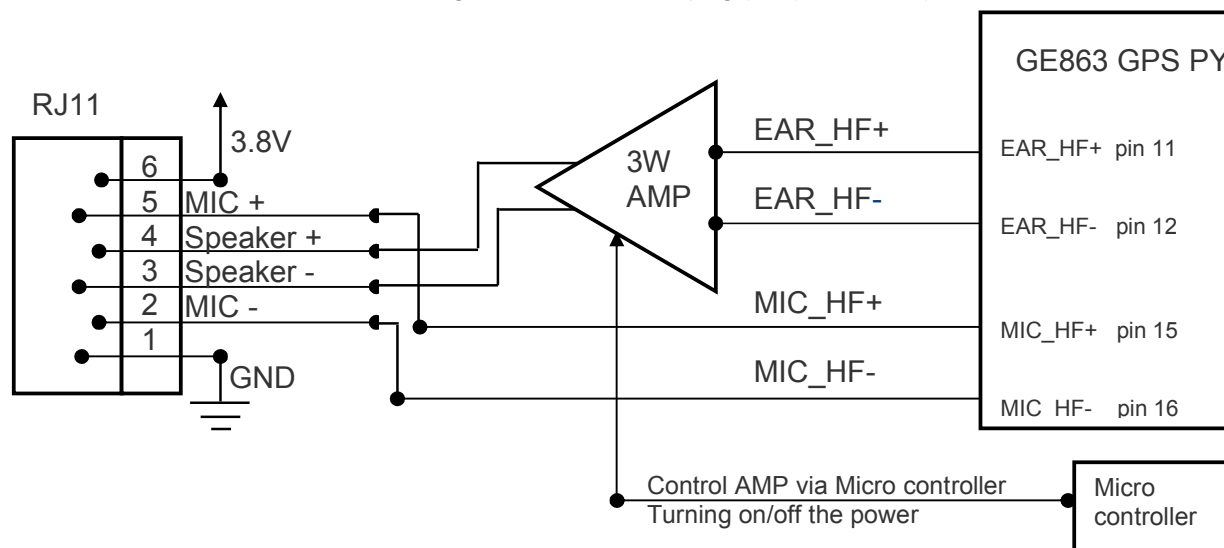

Figure 15: Audio block diagram

Sample Commands for EZ863 Audio operation

1	AT#CAP=	1	Audio Path
2	AT#SHFEC=	1	Echo Canceller
3	AT+CLVL=	0 - 14	Speaker Gain
4	AT#HFMICG=	0 - 7	Microphone Gain

Send in One Line all 4 AT command in top table	AT#CAP=1;#SHFEC=1;+CLVL=10;#HFMICG=3
Get Values	AT#CAP?;#SHFEC?;+CLVL?;#HFMICG?

2.7.1 Supported Audio Modes

The audio interface can be configured by AT commands. In audio mode HAND FREE, the default gain 4 in the MIC_HF and the default gain 10 in the EAR_HF.

Please note that the Hand Free audio interface is connected in the EZ863 GPS Terminal.

2.7 Antenna Interface

In order to send or receive data connect an external RF antenna to the SMA connector which is internally connected to the RF signal of the GSM module.

Please consider that the recommended antenna equipment has been chosen to achieve optimum RF performance when operating the EZ863 GPS Terminal.

NOTE: Before connecting the EZ863 GPS to a Power Supply source, a suitable Antenna shall be As accessory, a magnetic surface mount antenna with 2.5dB gain, 2.5m of coaxial cable and The antenna has to be installed with care in order to avoid any interference with other electronic devices and has to guarantee a minimum distance from persons (20 cm). In case this requirement cannot be satisfied, the system integrator has to assess the final product against the SAR For a good efficiency of the antenna and minimum interference with other electronic systems, a space of min. 40 cm around the radiating part should be free, at least of electrically conducting materials (except the ground plane on which it is attached). Less distance and less obstacles there are between the antenna connected to the EZ863 GPS Terminal and the antenna of the GSM/GPRS network base station, the less power is radiated by the Terminal under normal conditions and the higher is the safety margin in case of disturbances. A check of eventual interferences can be made when the EZ863 Terminal transmits at maximum power level to register to a GSM 900 network (see frequency channel numbers), The EZ863 GPS includes a SMA female, and class 4 (2W) co-axial connector for the antenna to be connected shall fulfill the following requirements:

Frequency range	Depending by frequency band(s) provided by the network operator, the customer shall use the most suitable antenna for that/those band(s)
Bandwidth	80 MHz in EGSM 900, 70 MHz if GSM 850, 170 MHz in DCS, 140 MHz PCS band
Gain	1.5dBi \leq Gain $<$ 3dBi (referenced to isotropic radiator)
Impedance	50 Ohm
Input power	$>$ 2 W peak power
VSWR absolute max	\leq 10:1
VSWR recommended	\leq 2:1

Table 5: Antenna specification

2.8.1 Operating Frequency

The operating frequencies in GSM, DCS, PCS modes are conform to the GSM specifications.

Mode	Freq. TX (MHz)	Freq. RX (MHz)	Channels (ARFC)	TX - RX offset
E-GSM-900	890.0 - 914.8	935.0 - 959.8	0 - 124	45 MHz
	880.2 - 889.8	925.2 - 934.8	975 - 1023	45 MHz
GSM-850	824.2 - 848.8	969.2 - 893.8	128 - 251	45 MHz
DCS-1800	1710.2 - 1784.8	1805.2 - 1879.8	512 - 885	95 MHz
PCS-1900	1850.2 - 1909.8	1930.2 - 1989.8	512 - 810	80 MHz

Table 6: Operating frequencies

Transmitter output power

GSM-850 / 900

The EZ863 GPS modem in GSM-850/900 operating mode are class 4 in accordance with the specification which determine the nominal 2W peak RF power (+33dBm) on 50 Ohm.

DCS-1800 / PCS-1900

The EZ863 GPS wireless modem in DCS-1800/PCS-1900 operating mode are of class 1 in accordance with the specifications which determine the nominal 1W peak RF power (+30dBm) on 50 Ohm.

Reference sensitivity

GSM-850 / 900

The sensitivity of the EZ863 GPS modem according to the specifications for the class 4 GSM-850/900 portable terminals is -107dBm typical in normal operating conditions.

DCS-1800 / PCS-1900

The sensitivity of the EZ863 GPS modem according to the specifications for the class 1 portable terminals DCS-1800 / PCS-1900 is -106 dBm typical in normal operating conditions.

2.9 SIM Interface

The SIM interface is intended for 3V SIM cards. The card holder is a five wire interface according to GSM 11.11. A sixth pin has been added to detect whether or not the SIM card drawer is inserted. Removing and inserting the SIM card during operation requires the software to be reinitialized. Therefore, after reinserting the SIM card it is necessary to restart EZ863 GPS Terminal.

2.10 IO Interface

The following interfaces and functions are provided via the IO interface connector.

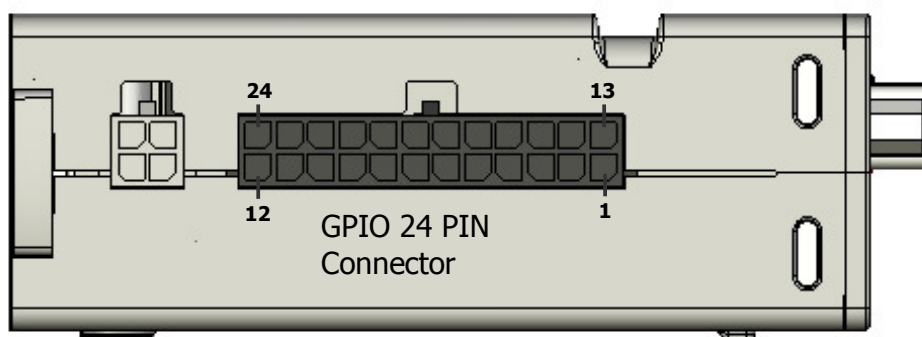

Figure 16: GPIO interface connector 24 pin

Pin	Signal name	I/O	Description
1	I2CCLK or GPIO3	I	I2C Clock or Input GPIO3 with Pull-up 4.7K
2	I2CDAT or GPIO4	I	I2C Data out or Input GPIO4 with Pull-up 4.7K
3	GPIO1	I	Input GPIO1 with Pull-up 47K
4	GPIO8	I	Input GPIO8 with Pull-up 47K
5	GPIO7	O	Output GPIO7 with 500ma max open collector (ULM2003)
6	GPIO2	O	Output GPIO2 with 500ma max open collector (ULM2003)
7	GPIO5	O	Output GPIO5 with 500ma max open collector (ULM2003)
8	GPIO13	O	Output GPIO13 with 500ma max open collector (ULM2003)
9	EMEROFF	I	When hook to GND will power off the internal power supply
10	RST	I	RST input to GE863 Modem, use to start the Modem on save mode
11	VMOD	O	Modem power supply normally 3.8V or battery power
12	GND		
13	Relay_a	O	Normally open Relay leg 1 (30V 1A max)
14	Relay_b	O	Normally open Relay leg 2 (30V 1A max)
15	GPIO12	I	Input GPIO12 with Pull-up 47K
16	GPIO11	I	Input GPIO11 with Pull-up 47K
17	GPIO15	I	Input GPIO15 with Pull-up 47K
18	GPIO16	I	Input GPIO16 with Pull-up 47K
19	PWRMON	O	When modem is ON this pin will be high 2.8V
20	On/Off	I	Turn ON and OFF the modem
21	ADC1	I	analog input 1
22	PPS	I	
23	GND	O	
24	VIN	I	Input Power Supply

Table 7: Assignment of the IO interface connector

Sample Commands for EZ863
GPIO operation

CONTROL GPIO 7

AT#GPIO=7,1,1 // ON
AT#GPIO=7,0,1 // OFF

CONTROL GPIO 2

AT#GPIO=2,1,1 // ON
AT#GPIO=2,0,1 // OFF

CONTROL GPIO 5

AT#GPIO=5,1,1 // ON
AT#GPIO=5,0,1 // OFF

CONTROL GPIO 13

AT#GPIO=6,1,1 // ON
AT#GPIO=6,0,1 // OFF

GPIO Check inputs

AT#GPIO?

#GPIO: 0,1 // GPIO 1
#GPIO: 0,0 // GPIO 2
#GPIO: 0,1 // GPIO 3
#GPIO: 0,1 // GPIO 4
#GPIO: 1,0 // GPIO 5
#GPIO: 1,0 // GPIO 6
#GPIO: 1,0 // GPIO 7
#GPIO: 0,1 // GPIO 8
#GPIO: 0,1 // GPIO 9
#GPIO: 0,0 // GPIO 10
#GPIO: 0,1 // GPIO 11
#GPIO: 0,1 // GPIO 12
#GPIO: 0,0 // GPIO 13
#GPIO: 0,1 // GPIO 14
#GPIO: 0,1 // GPIO 15
#GPIO: 0,1 // GPIO 16
#GPIO: 0,0 // GPIO 17
#GPIO: 0,1 // GPIO 18

#GPIO: A,B

A = 0 define IO as Output

A = 1 define IO as Input

B = Input Level

2.10.1 GPIOs

The EZ863 GPS Terminal provides 8 GPIO pins at the 24 pins interface connector. Each GPIO line is ESD protected and a serial resistor of 100 Ohm is added. This avoids short circuits, The signal direction (input/output) of the GPIO lines is selectable with AT commands. Figure 11 shows the position of the GPIO pins at the IO interface connector. When the EZ863 GPS Terminal starts up, all GPIO pins are set to high-impedance state after initializing, There for internal pull-up resistors Of 47k to all pins you use as input. This is necessary to keep these pins from floating or driving any external devices before all settings are done by AT command. The EZ863 GPS Terminal provides 4 GPIO pins at the O interface connector. Each GPIO line is ESD protected and a serial resistor of 100 Ohm is added, all this 4 outputs drive via ULN2003A open collector driver maximum output current 500ma each GPIO.

Using the RFTX Output GPIO5

The GPIO5 pin, when configured as RFTX Output, is controlled by the GE863 GPS module and will rise when the GE863 GPS starts transmit and fall after stop to transmit.

Using the Alarm Output GPIO6

The GPIO6 pin, when configured as Alarm Output, is controlled by the GE863 GPS module and will rise when the alarm starts and fall after the issue of a dedicated AT command. This output can be used to power up the EZ863 GPS controlling microcontroller or application at the alarm time, giving you the possibility to program a timely system wake-up to achieve some periodic actions and completely turn off either the application and the GE863 GPS during sleep periods, dramatically reducing the sleep consumption to few μ A. In battery powered devices this feature will greatly improve the autonomy of the device.

Using the Buzzer Output GPIO7

The GPIO7 pin, when configured as Buzzer Output, is controlled by the GE863 GPS module and will drive with appropriate square waves a Buzzer driver. This permits to your application to easily implement Buzzer feature with ringing tones or melody played at the call incoming, tone playing on SMS incoming or simply playing a tone or melody when needed by your application.

2.10.3 I²C Interface

The I²C interface is located at the 24 pins interface connector of the EZ863 GPS Terminal. I²C is a serial, 8-bit oriented data transfer bus for bit rates up to 10kbps. It consists of two lines. These are the serial data line I2CDAT and the serial clock line I2CCLK. The EZ863 GPS Terminal acts as a single master device, e.g. the clock I2CCLK is driven by the Terminal. The connection I2CDAT is a bi-directional line. Each device which is connected to the bus is software addressable by a unique address and simple master/slave relationships exists at all times. The Terminal operates as master transmitter or as master-receiver. The customer application transmits or receives data only on request of the Terminal. To configure and activate the I²C interface use the AT command described in Telit AT command Guide. The I²C interface is only available if the pins 1 and 2 of the IO interface connector are not used as GPIO interface.

Signal name	24 Pins connector	Description
I2CDAT_SPIDO	Pin No. 1	Data in/out – bidirectional serial data line
I2CCLK_SPICLK	Pin No. 2	Serial clock line

Table 8: I²C interface – signal description

2.10.4 Analog-to Digital Converter (ADC)

The analog input is used for measuring external DC voltages in a range of 0V to 2.0V.

Note: Only positive voltage can be handled because of the input requirement of ADC.

Signal name	24 Pins connector	Description
ADC1_IN	Pin No. 21	Analog input 1 to GE863 pin 73
ADC1_IN	No output	Option: Analog input 1 to GE863 pin 73 Connected internally to input voltage

Table 9: ADC signal description

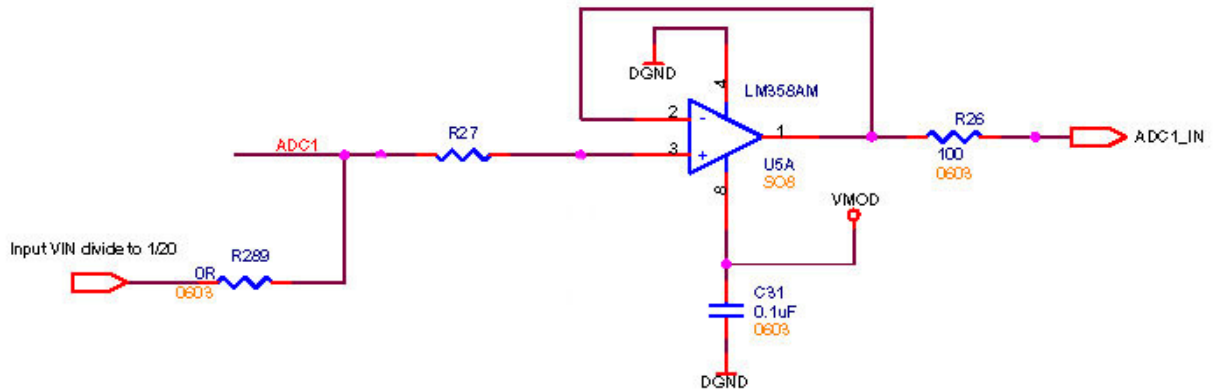

Figure 17: ADC amplifier for ADC1

Use the command AT To configure and activate the analog inputs and to get the measurement results. The unit set up for measuring 4-20 ma sensors, with 100 ohm resistor on the input.

Note: It is necessary to recalculate measurement results because the input resistors are used to scale down the ADC1_IN input voltage of the EZ863 GPS Terminal to the ADC1_IN input voltage of the in-built GE863 GPS module (2.0V).

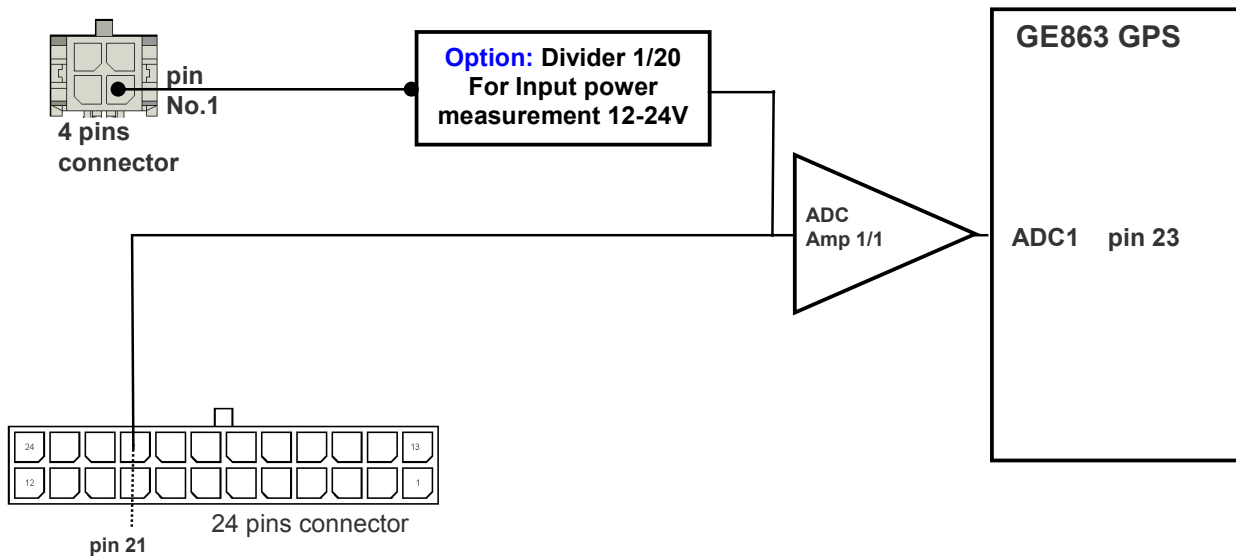

Figure 18: Connections for ADC1

A/D is 11-bit converter. It is able to read a voltage level in the range of 0÷2 volts applied on the ADC pin input, store and convert it into 11 bit word, Resolution - < 1 mV.

The command use the ADC function is AT#ADC=1,2 The read value is expressed in mV.

2.10.5 Power Supply

The two pins of the power supply at the 24 pins interface connector are directly connected to two pins of the power supply 4 pin connector. This allows supplying the EZ863 GPS Terminal by using the Power connector or via the 24 pin connector interface connector.

2.10.6 PWRMON

The PWRMON pin 19 at the 24 pins interface connector may be used for supplying external circuit devices or applications and indicates the following states of the EZ863 GPS Terminal:

- PWRMON output voltage = 2.8V @ max. 50mA indicates modem on Operation mode.
- PWRMON output voltage = 0V indicates modem is in Power Down mode.

2.10.7 On/Off Switch

If the On/Off pin 20 at the 24 pins interface connector is active low. It can be used to switch on or switch off the EZ863 GPS PY Terminal. For more information on how to switch on or switch off the Terminal please refer to the Telit GE863 GPS command guide.

2.10.8 IGINATION option

IGATION pin 9 at the 24 pins interface connector, when active low, the EZ863 GPS Terminal switch OFF. IGINATION pin at the 24 pins interface connector, when active high, the EZ863 GPS Terminal switch ON. This pin controls the internal DC to DC power supply.

2.10.9 Relay

The internal Relay pins 13,14 at the 24 pins interface connector may be used for controlling external circuit devices or applications. The relay parameters:

- Maximum voltage = 30V @ max. 1A.
- The Relay is normally open.

The Relay output control by GPIO17, control by AT command.

Sample Commands for Relay operation

AT#GPIO=17,1,1	Relay On
AT#GPIO=17,1,0	Relay Off

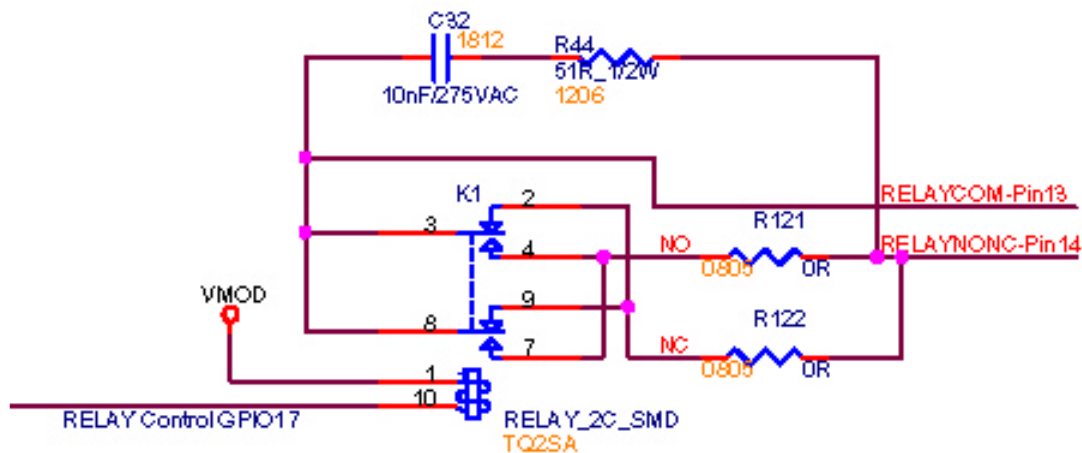

Figure 19: Relay Control

2.10.10 VMOD Supply

The VMOD pin 11 at the 24 pins interface connector may be used for supplying external circuit devices or applications. The VMOD is the same power supply to GE863 GPS, The VMOD parameters:

- VMOD output voltage = 3.8V max. 0.2A.
- VMOD output voltage when LIPO battery use = 3.4V - 4.2V

2.10.11 RTS

The RTS pin 10 at the 24 pins interface connector may be used for start up the GE863 GPS when GE863 GPS is in save mode external circuit devices or applications can pull down this pin and turn on the GE863 GPS. This pin can be very helpful on PYTHON script application.

The EZ863 GPS can wake up from save mode few ways:

- RTS pin PULL DOWN
- Internal RTC
- Call or SMS arrive to EZ863 GPS unit.

2.11 Status LED

Red LED displays the network status of the EZ863 GPS Terminal.

Red LED status	Device Status
permanently on	a call is active
fast interrupt sequence (period 0,5s, Ton 1s)	Net search / Not registered / turning off
slow interrupt sequence (period 0,3s, Ton 3s)	Registered full service
permanently off	device off

Table 10: RED LED Status

Green LED displays the operating status of the GPIO10 in the EZ863 GPS Terminal control by AT command or by PYTHON script.

Sample Commands for Green led operation

AT#GPIO=10,1,1	Led On
AT#GPIO=10,1,0	Led Off

3. GPS

3.1 GPS Antenna Requirements

The GE863 GPS module is not provided with an internal LNA amplifier. The use of an active antenna is important to achieve a good performance.

The module is provided of an Antenna supply circuit with the following characteristics:

- Supply voltage referred to VBATT (3.4 to 4.2 V DC)
- Supply enable controlled internally by the BB
- Current measurement circuit (readable also with AT commands)
- Voltage measurement circuit (readable also with AT commands)
- HW Protection for Antenna Short Circuit (if consumption exceeds 40mA)

As suggested on the Product Description the external active antenna for a EZ863 GPS device shall fulfill the following requirements:

ANTENNA REQUIREMENTS	
Frequency range	1575.42 MHz (GPS L1)
Bandwidth	+ - 1.023 MHz
Gain	1.5 dBi < Gain < 4.5 dBi
Impedance	50 ohm
Amplification	Typical 25dB (max 27dB)
Supply voltage	Must accept from 3 to 5 V DC
Current consumption	Typical 20 mA (40 mA max)

Table 11: GPS Antenna requirements

4. Mechanical Characteristics

Weight	160g
Dimensions (max) L x W x H	98 mm x 82mm x 30mm
Temperature range	-20°C to +70°C ambient temperature
Protection class	IP40 Avoid exposing EZ863 Terminal to liquid or moisture
Mechanical vibrations Amplitude	7.5mm at 5-200Hz sinus
Air humidity	5% - 85%
Class of flammability	UL94 HB
Casing material	PC/ABS Cyclopedia 1200 HF

Table 11: Mechanical characteristics

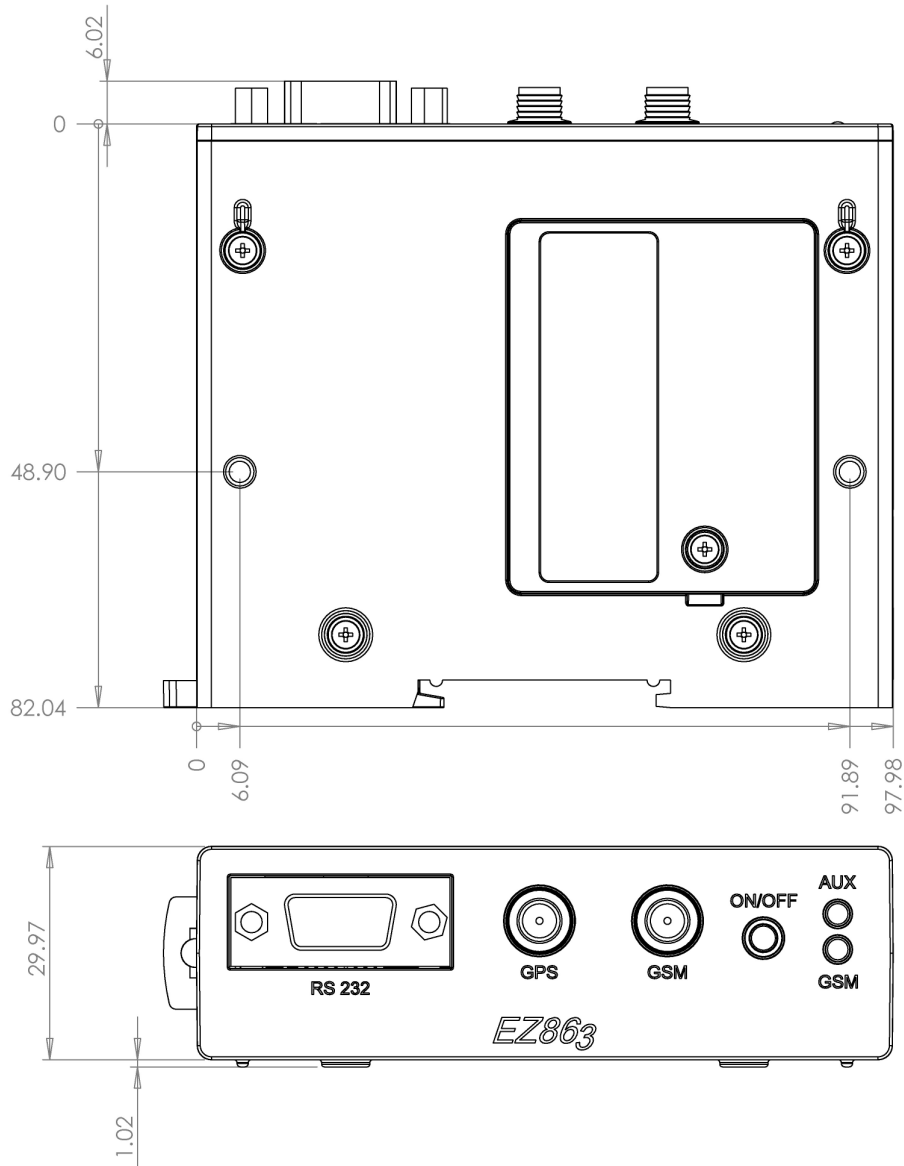

Figure 20: Mechanical measurements

5. ACCESSORIES

5.1 24 pins Interface Connector

This chapter provides specifications for the 24-pin IO interface connector which serves the GPIO interfaces of the Terminal. The type of the receptacle assembled on the EZ863 GPS Terminal is 24 pin Micro Mate-N-LOK 3mm from MOLEX. Mating headers can be chosen from the MOLEX Micro Mate-N-LOK Series. For latest product information <http://www.molex.com>

5.2 Power Supply

This chapter provides specifications for the power supply which serves the Terminal. The power supply we recommended is 12V 1.2A part number EZ12V1.2A. The type of the receptacle assembled on the EZ863 GPS Terminal is 4 pin Micro Mate-N-LOK 3mm from MOLEX. Mating headers can be chosen from the MOLEX Micro Mate-N-LOK Series. For latest product information <http://www.molex.com>

5.3 Battery

This chapter provides specifications for the Battery which serves the Terminal. The LIPO battery we recommended is 3.7V 900mA/h part number EZBattery900 mechanical size 38*39*6.1mm. The type of the receptacle assembled on the EZ863 GPS PY Terminal is 2 pin Micro Mate-N-LOK 2.54mm from MOLEX. Mating headers can be chosen from the MOLEX Micro Mate-N-LOK Series. For latest product information <http://www.molex.com>

5.4 Power cable

This chapter provides specifications for the power cable which serves the Terminal. The power supply we recommended is 30V 1.2A part number EZPowerCable. The type of the receptacle assembled on the EZ863 GPS Terminal is 4 pin Micro Mate-N-LOK 3mm from MOLEX. Mating headers can be chosen from the MOLEX Micro Mate-N-LOK Series. For latest product information <http://www.molex.com>

5.2 GSM antenna

This chapter provides specifications for the GSM antennas which serves the Terminal.

We recommended 4 types of GSM antennas with SMA connector:

900/1800Mhz 2.5dBm 3 meter cable part number EZantenna2.5db3M9001800.

850/1900Mhz 2.5dBm 3 meter cable part number EZantenna2.5db3M8501900.

900/1800/1900Mhz 1dBm 5 cm 90 degree SMA part number EZantenna1db5m90018001900SMA.

5.2 GPS antenna

This chapter provides specifications for the GPS antennas which serves the Terminal.

We recommended 2 types of GPS antennas with SMA connector:

1500Mhz 5 meter cable part number EZantennaGPS5m.

Part Number	Accessory name	Accessory Image
CabRS232	Cable RS232 1.8m Dtype 9pin	
Cab24p24w	Cable 24pin 24wire 40cm 24g	
Bat960	Battery 960ma/H 6.1*39*38mm	
Cab24p4w	Cable relay 24pin 4wire 2m 24g	
AntGSMGPS	Antenna GSM GPS 3m SMA	

Part Number	Accessory name	Accessory Image
AntGPS1	Antenna GPS 5m SMA	
AntGSM3m2b	Antenna GSM 2band 3m SMA	
AntS5cm	Antenna S GSM 4band 5cm SMA	
AntR5cm	Antenna R GSM 4band 5cm SMA	
Cab4p4w	Cable power 4pin 4wire 2m 24g	
PS1UK	Power supply 12V1.2A 4pin UK	
PS1EU	Power supply 12V1.2A 4pin EU	

6. SAFETY RECOMMENDATIONS

READ CAREFULLY

Be sure the use of this product is allowed in the country and in the environment required. The use of this product may be dangerous and has to be avoided in the following areas:

Where it can interfere with other electronic devices in environments such as hospitals, airports, aircrafts, etc. Where there is risk of explosion such as gasoline stations, oil refineries, etc

It is responsibility of the user to enforce the country regulation and the specific environment regulation. Do not disassemble the product; any mark of tampering will compromise the warranty validity. We recommend following the instructions of the hardware user guides for a correct wiring of the product. The product has to be supplied with a stabilized voltage source and the wiring has to be conforming to the security and fire prevention regulations. The product has to be handled with care, avoiding any contact with the pins because electrostatic discharges may damage the product itself. Same cautions have to be taken for the SIM, checking carefully the instruction for its use. Do not insert or remove the SIM when the product is in power saving mode. The system integrator is responsible of the functioning of the final product; therefore, care has to be taken to the external components of the module, as well as of any project or installation issue, because the risk of disturbing the GSM network or external devices or having impact on the security. Should there be any doubt, please refer to the technical documentation and the regulations in force. Every module has to be equipped with a proper antenna with specific characteristics. The antenna has to be installed with care in order to avoid any interference with other electronic devices and has to guarantee a minimum distance from the body (20 cm). In case of this requirement cannot be satisfied, the system integrator has to assess the final product against the SAR regulation. The European Community provides some Directives for the electronic equipments introduced on the market. All the relevant information's are available on the European Community website: <http://europa.eu.int/comm/enterprise/rtte/dir99-5.htm> The text of the Directive 99/05 regarding telecommunication equipments is available, while the applicable Directives (Low Voltage and EMC) are available at:

http://europa.eu.int/comm/enterprise/electr_equipment/index_en.htm

7. EZ863 GPS Options

This chapter provides options that can be use on the EZ863 GPS.

7.1 Battery Source Power

7.1.1 Battery Power

Single 3.7V LIPO cell battery type is use for supplying the power to the EZ863 GPS The battery capacity 900mAh.

7.1.2 Battery Charge control Circuitry

The charging process for LIPO Battery divided into 4 phases:

- Qualification and trickle charging
- Fast charge 1 - constant current
- Final charge - constant voltage or pulsed charging
- Maintenance charge

The qualification process down by special internal chip, this chip is battery charger voltage regulator. moreover all these operations should start only if battery temperature is inside a charging range, usually 5°C - 45°C. The EZ863 GPS measures the temperature of its internal component, in order to satisfy this last requirement, it's not exactly the same as the battery temperature but in common application the two temperature should not differ too much and the charging temperature range should be guaranteed.

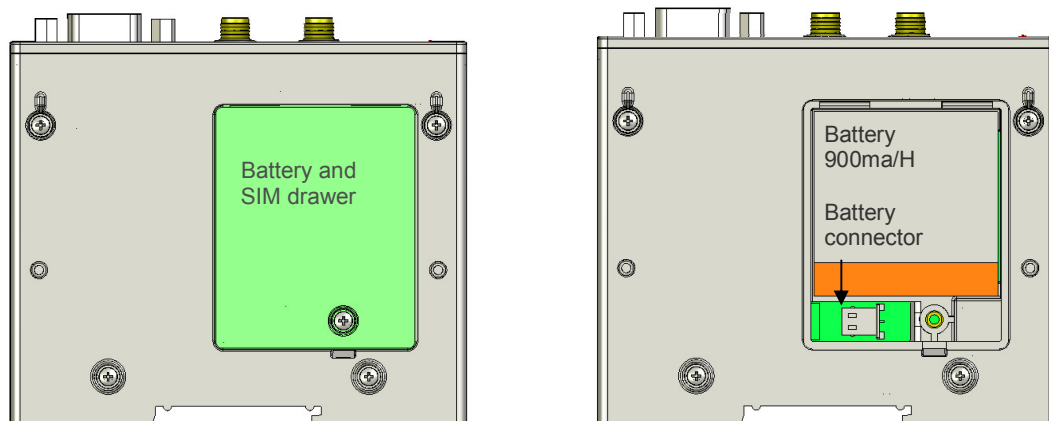

Figure 21: EZ863 GPS Terminal bottom view LIPO Battery location